

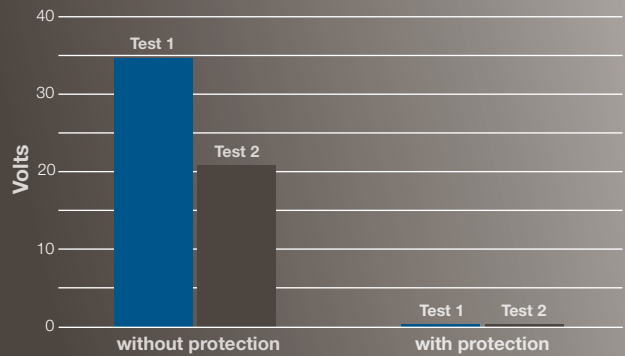

Bearing Gard™ Bearing Isolator With Electrical Grounding

Bearing Gard isolators with AEGIS® grounding ring technology provide superior reliability and extended life for electric motors using variable frequency drives.

VFD induced shaft voltage



Complete motor protection

The growing population of Variable Frequency Drives (VFDs) as motor controllers has revealed electrical grounding through the bearings to be a major cause of premature motor failure. The Bearing Gard with electrical grounding is specifically designed to prevent motor failure from electrical fluting and contamination ingress.

- Bearing Gard technology provides superior static and dynamic protection against contamination ingress
- AEGIS bearing protection ring utilizes Electron Transport Technology™ and conductive microfibers™ to provide the most reliable current diversion technology
- Prevents electrical discharge damage, including fluting in bearings
- Protects against lubrication breakdown due to electrical arcing and contamination
- Standard design accommodates axial shaft movement of 0.63 mm (0.025 in) TIR

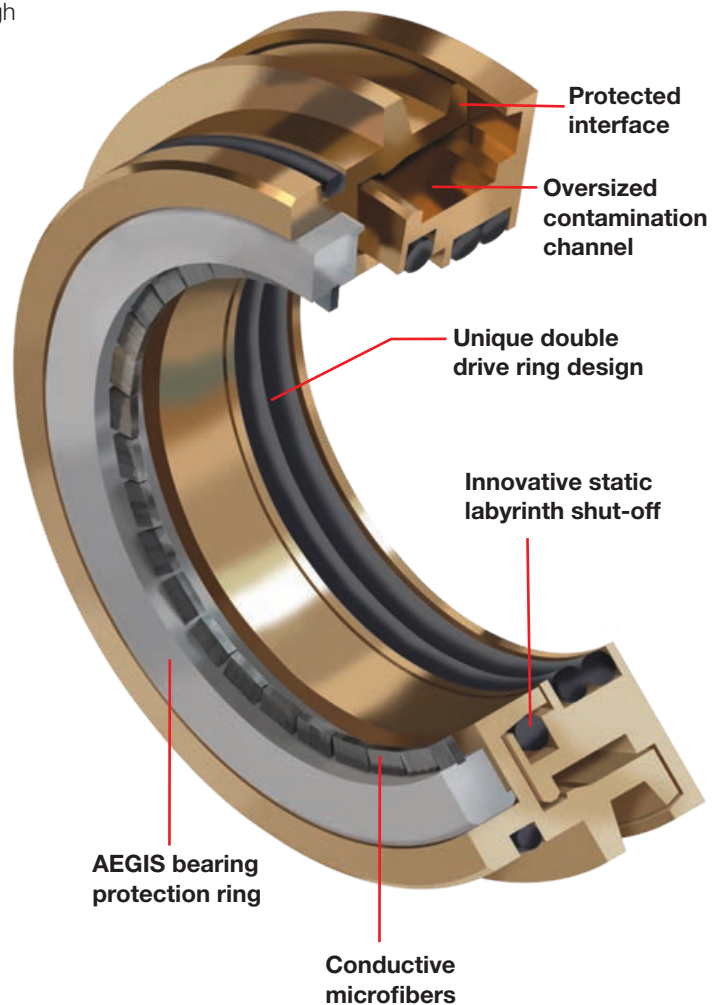
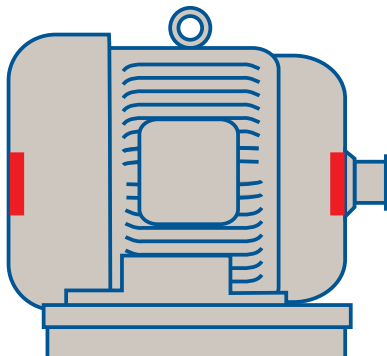



Bearing Gard™ Bearing Isolator With Electrical Grounding

Custom sizes ship in two days or less

Working to keep industry running, Flowserve offers the Bearing Gard with electrical grounding in many stocked sizes. Custom sizes ship in two days or less.

General guidelines for electrical grounding designs:

| | |
|------------------------|--|
| Shaft diameters | 23–152 mm (0.875–6.000 in) |
| Housing bore | 20–50 mm (0.750–2.000 in) over shaft diameter |
| Lengths | Standard and slimline (see cross-section view) |
| Maximum axial movement | 0.63 mm (0.025 in) TIR |
| Maximum radial runout | 0.13 mm (0.005 in) TIR |
| Shaft temperature | to 190°C (375°F) |
| Speed | to 5000 rpm |
| Rotor and stator | bronze |
| O-rings | Fluoroelastomer |
| Bearing lubrication | grease or dry lubrication |

Reliable discharge of voltage



VFD motor without protection discharges 20.8 V through the bearings.

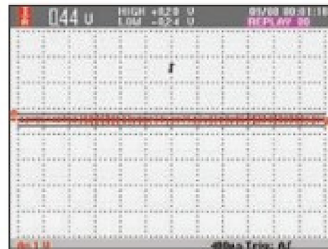

VFD motor and Bearing Gard with electrical grounding provide a 98% drop in shaft voltage.

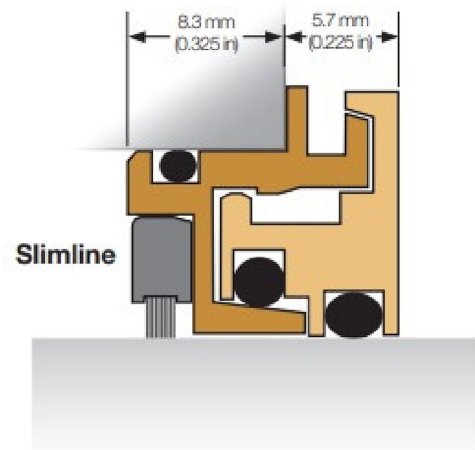
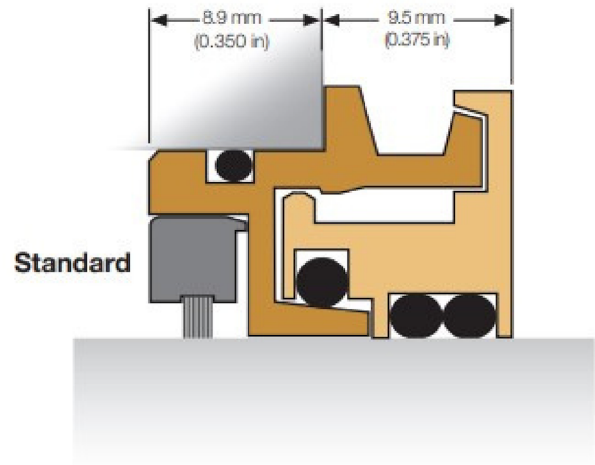

AEGIS® is a registered trademark of Electro Static Technology, an ITW Company. All rights reserved.

